

M-SWITCH

MEASUREMENT SOLUTIONS INC.

The M-Switch series of adjustable mounts are designed to redirect a horizontal interferometric set-up to a vertical one.

The perfect blend of innovative design and cutting edge technology

Specifications

- This vertical alignment keeps gravity on your side
- Enables fast alignment of optics to the interferometer
- Eliminates the induced error from bending and stress points when holding the edge horizontally.
- Reduces potential damage from edge stress and optics falling over when holding against gravity

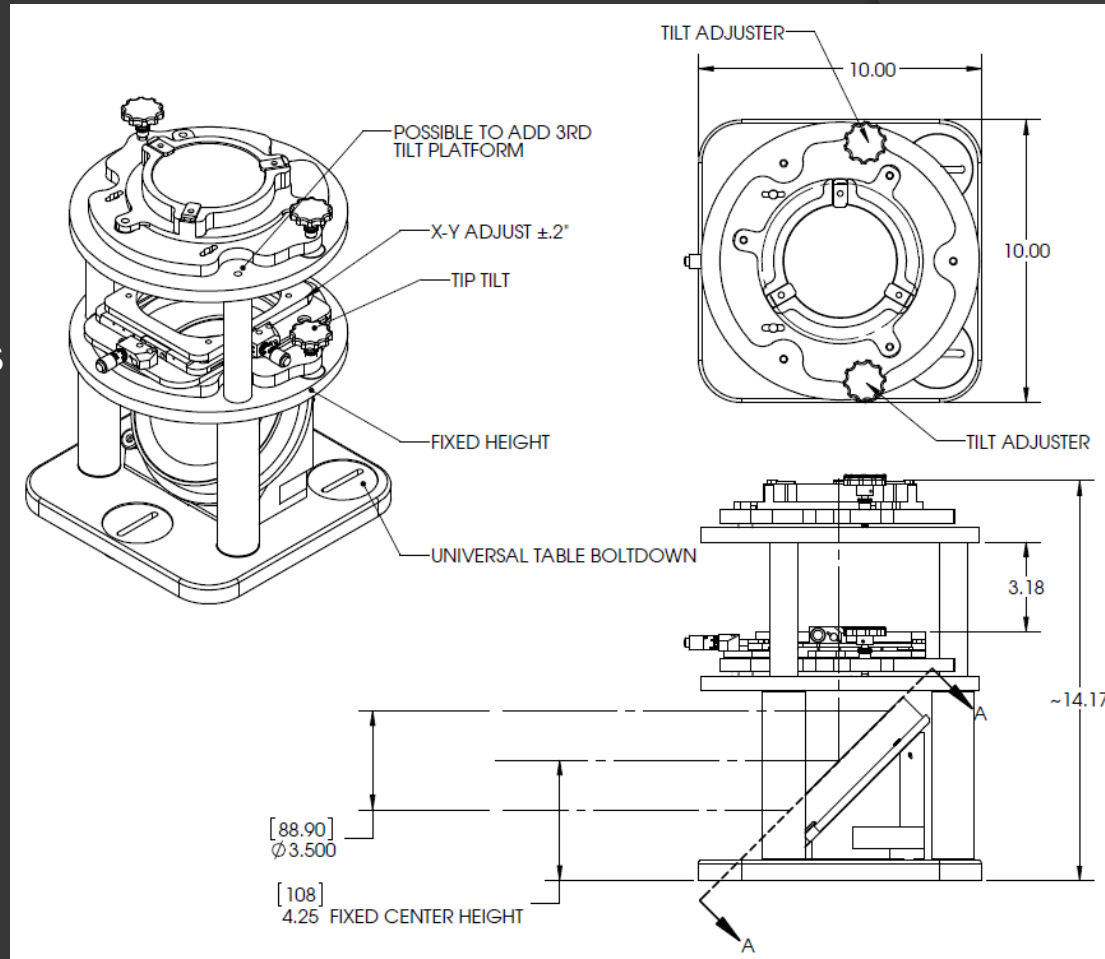

Range and Capabilities



- Angle range $\pm 2^\circ$
- X-Y range $>.2''$
- Variable aperture fixture allows adjustable diameters from 1mm to 102mm
- Riser post can be installed to increase table height
- XYZ table may be installed on top tilt plate for confocal testing of lenses and lens assemblies
- CGH mount can also be integrated for null testing



Mirror or Window Testing

- **1st level**

- Tip/tilt stage
- Adapter
- 3 arm part holder
- Mirror protector

- **2nd level**

- Tip/tilt stage
- Return mirror



Lens Testing with CGH or Null

1st level

- Tip/tilt stage
- X-Y adjust stage
- 3 arm part holder
- Mirror protector

2nd level

- Tip/tilt stage
- X-Y adjust stage
- Z stage

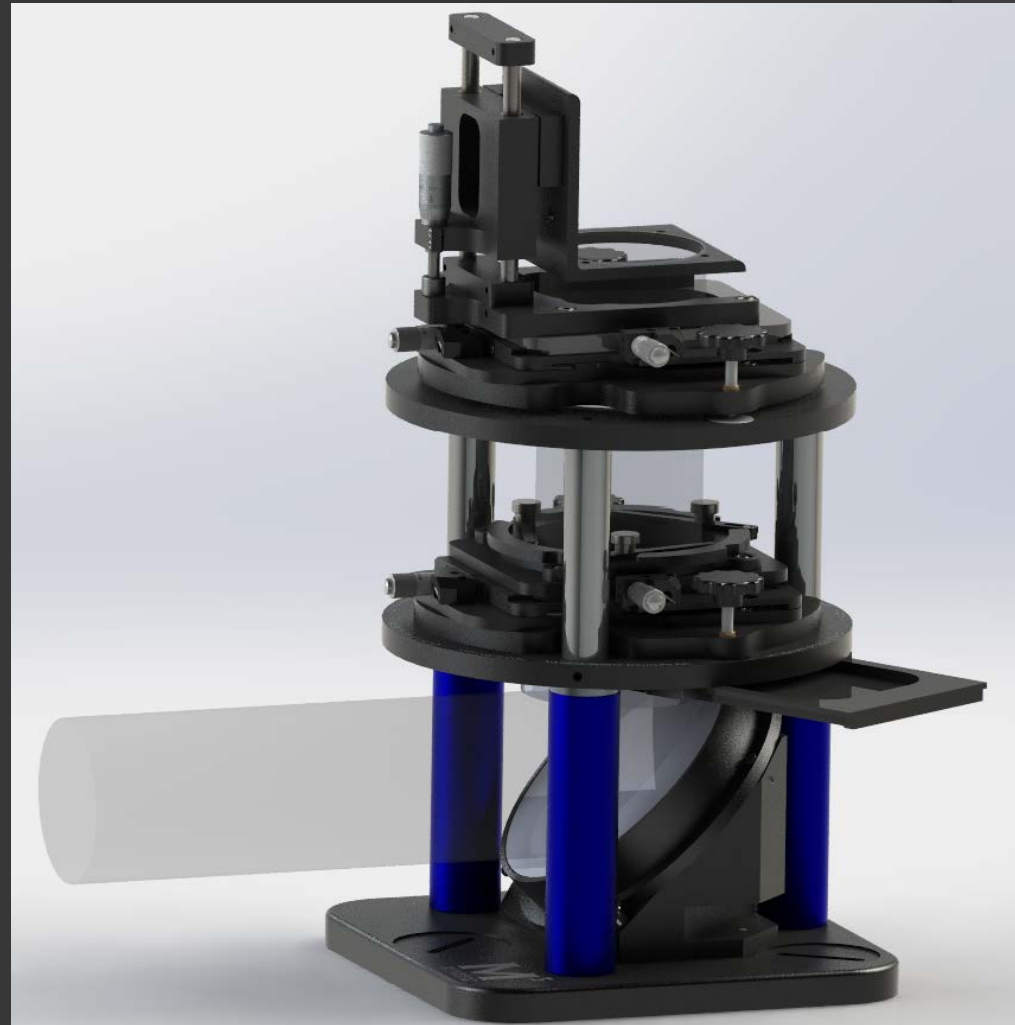

Lens Assembly Testing

1st level

- Tip/tilt stage
- Adapter
- Part holder
- Mirror protector

2nd level

- Tip/tilt stage
- X-Y stage
- Z-Stage

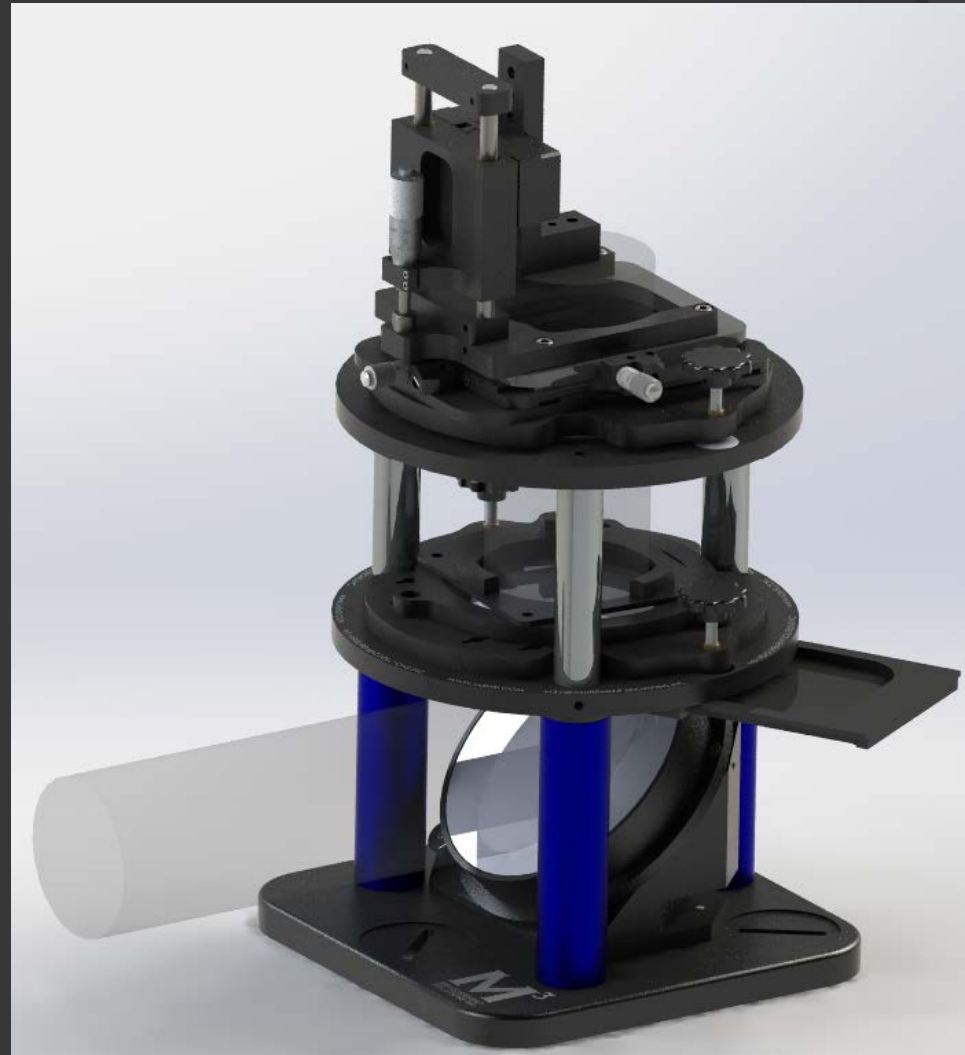

Variable Part Holder

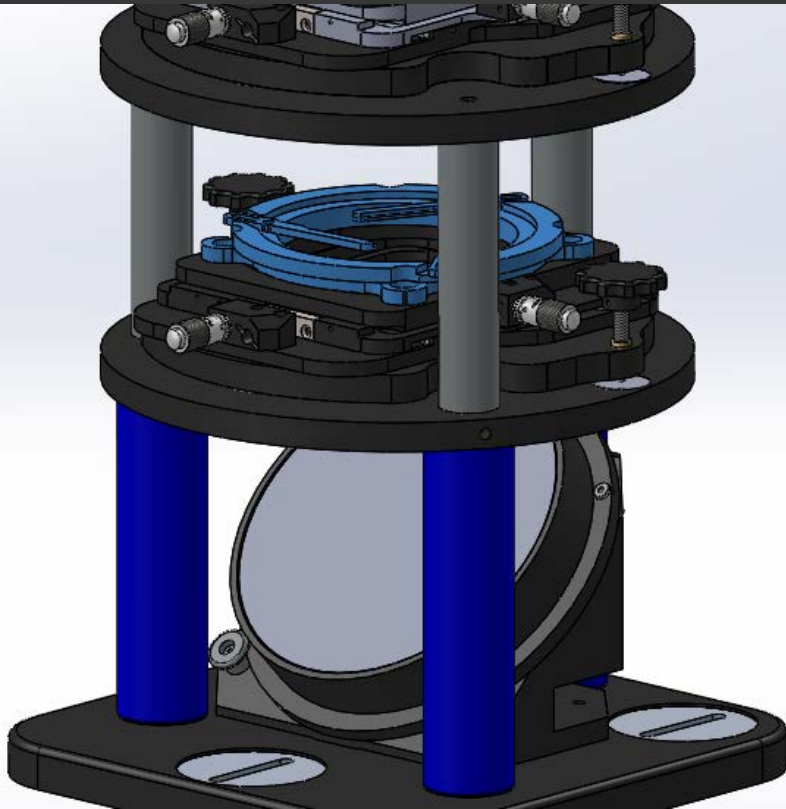

Measurement Solutions Inc.

938 S Andreasen Drive, Suite I, Escondido, CA USA 92029

www.m3msi.com 760-561-1400

E-mail: Sales@m3msi.com

Kinematic Part Holder

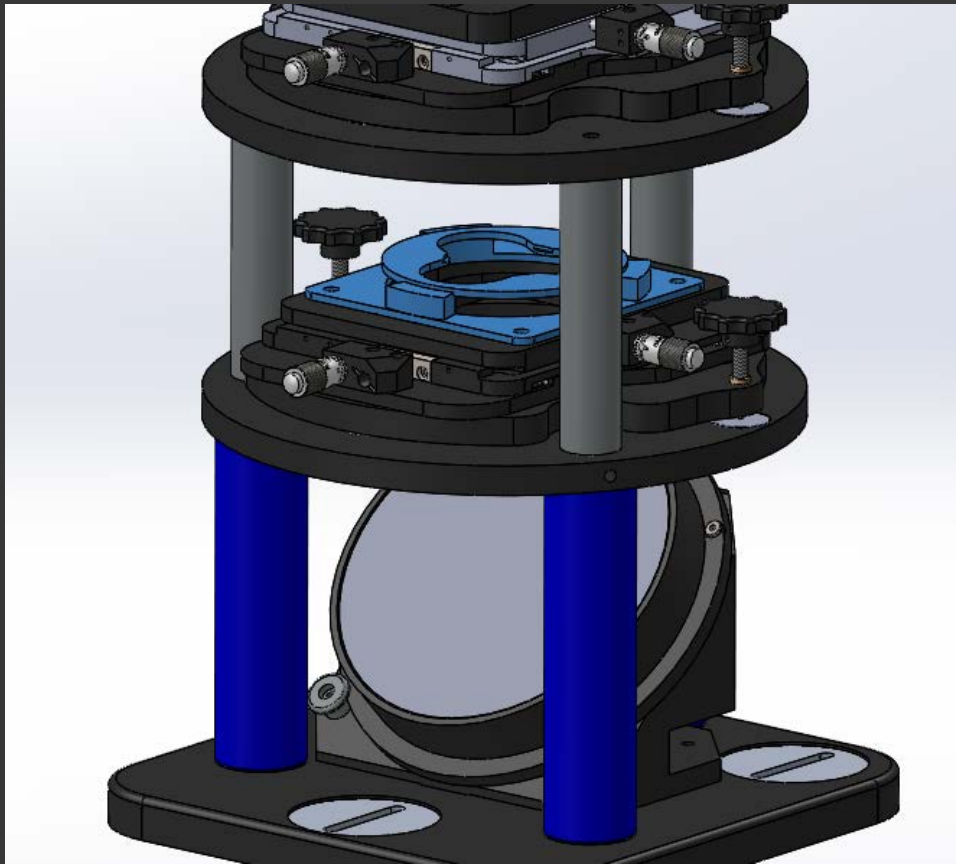

Measurement Solutions Inc.

938 S Andreasen Drive, Suite I, Escondido, CA USA 92029

www.m3msi.com 760-561-1400

E-mail: Sales@m3msi.com

Variable Z-axis null reflector

Z-axis offers 3 types of adjustment for a total range of 9" (228mm):

- GROSS ADJUST BOLTS POSITIONER EVERY .5"
- COURSE ADJUST IS DOVETAIL WITH LOCK 2"
- MICROMETER ADJUST IS +/- 0.5" (12.7mm)



Variable Z-axis Part Holder

**Z Stage, Bolts directly to
X-Y STAGE.**

3 types of Z adjustment.

- **6" bolt adjust**
- **2" Dovetail Slide**
- **1" MICROMETER**
- **3.25" OPENING**
- **1/4-20 TAPPED HOLE
FOR CUSTOMER
ATTACHMENT POINTS**



Measurement Solutions Inc.

938 S Andreasen Drive, Suite I, Escondido, CA USA 92029

www.m3msi.com 760-561-1400

E-mail: Sales@m3msi.com